

ClearClick® All-In-One Vintage-Style Turntable *(Model VT33)*

Quick Start Guide & User's Manual



5-Year Warranty +

FREE USA-Based Tech Support

If you have any issue or question regarding this product, **contacting us directly** is the fastest way to resolve the issue. We are ClearClick®, a small USA-based business, and we stand behind our products with a 5-year warranty & free USA tech support. If you have any issues with our product, **please contact us at support@clearclick.com**.



www.ClearClick.com

Extend Your Warranty for FREE!

Extend your warranty by one year for free simply by registering your product at: www.ClearClick.com

Thank You!

Thank you for your purchase of the ClearClick® All-In-One Vintage-Style Turntable (VT33)! We appreciate your business.

At ClearClick®, we try to make our technology as clear to understand and use as possible. But if you get stuck at any point, you qualify for FREE USA-based tech support as a ClearClick® customer. Just email us at: support@clearclick.com

(Make sure you explain your issue in detail and tell us that you're using our ClearClick® All-In-One Vintage-Style Turntable, Model VT33). Our USA-based tech support team members will normally reply to you within 24-48 business hours, usually sooner.)

Safety Instructions – Please Read & Follow

WARNING: DO NOT EXPOSE THIS APPLIANCE TO RAIN OR MOISTURE.

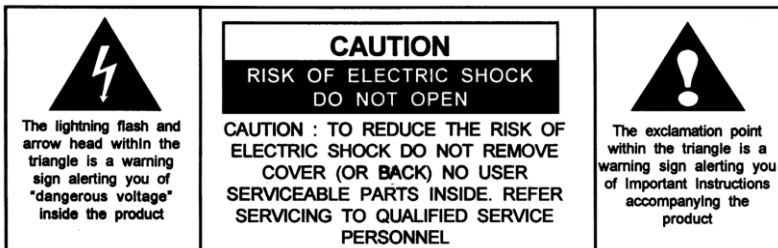

Safety Instructions (Continued)

1. **!! NORTH AMERICAN VOLTAGE ONLY!! Outside North America, this product requires a voltage transformer. Using this device with voltage over 120V will instantly destroy the device.**
2. Keep these instructions.
3. Heed all Warnings.
4. Follow all instructions and do NOT allow children around this device.
5. Do not use this apparatus near water or spill liquids on it.
6. Clean only with a dry cloth.
7. Do not block any ventilation openings. Install in accordance with the manufacturer's instructions.
8. Do not install near any sources such as radiators, heat registers, stoves, or other apparatus (including amplifiers) that produce heat.
9. Do not defeat the safety purpose of the polarized or grounding –type plug. A polarized plug has two blades with one wider than the other. A grounding type plug has two blades and a third grounding prong. The wide blade or the third prong are provided for your safety. When the provided plug does not fit into your outlet, consult an electrician for replacement of the obsolete outlet.
10. Protect the power cord from being walked on or pinched particularly at plug, convenience receptacles, and the point where they exit from the apparatus.
11. Only use attachments/accessories specified by the manufacturer.
12. Unplug this apparatus during lightning storms or when unused for long periods of time.
13. Refer all servicing to qualified service personnel. Servicing is required when the apparatus has been damaged in any way, such as power-supply cord or plug is damaged, liquid has been LED or objects have fallen into the apparatus, the apparatus has been exposed to rain or moisture, does not operate normally, or has been dropped.

QUICK START – Setting Up The Device

1. Securely plug the power plug into a power outlet.

!! Important Note For Users Outside USA, Canada, and Mexico !! This device is ONLY compatible with standard North American 110V-120V voltage. DO NOT USE WITH VOLTAGES OVER 110V-120V, as this will instantly and permanently damage the device!

2. Turn on the device by pushing the “VOLUME” (right) knob inward.
3. Set the “FUNCTION” (left) knob to the desired function.

QUICK START – Listening To AM/FM Radio

1. Turn on the device by pressing the “VOLUME” (right) knob inward.
2. Set the “FUNCTION” (left) knob to “AM” or “FM.”
3. Rotate the “TUNING” knob to set the desired radio station.
4. Use the volume control knob to adjust the volume.

QUICK START – Playing Records

1. Turn on the device by pressing the “VOLUME” (right) knob inward.
2. Set the “FUNCTION” (left) knob to “PHONO.”
3. Set the SPEED SELECTOR to 33, 45 or 78 RPM according to the speed of the record.
4. Remove the stylus guard of the tone arm and place the tone arm on the record carefully.
5. Use the volume control knob to adjust the volume.

At the end of record, lift up the tone arm and return it to tone arm rest carefully.

QUICK START – Playing CDs

1. Turn on the device by pressing the “VOLUME” (right) knob inward.
2. Set the “FUNCTION” (left) knob to “CD.”
3. Press the OPEN/CLOSE button to open the CD door.
4. Place a CD in the tray with the labeled side facing up.
5. Press the OPEN/CLOSE button again to close the CD

door.

6. Press the PLAY/PAUSE button to start playback.
7. To pause playback, press the PLAY/PAUSE button.
Press the PLAY/PAUSE button again to resume playback.
8. To stop playback, press the STOP button.
6. Use the volume control knob to adjust the volume.
7. To repeat a single track, choose the track that you want to repeat, then press the PLAY BUTTON to start the track. Press the REPEAT BUTTON once to repeat this track.
8. To repeat all tracks, press the REPEAT twice to repeat all tracks. Once the CD ends, it will start over again from the beginning of the CD.

QUICK START – Playing Cassette Tapes

1. Turn on the device by pressing the “VOLUME” (right) knob inward.
2. Set the “FUNCTION” (left) knob to “TAPE.”
3. Insert a tape into the cassette slot (right side of device).
Ensure the tape is fully inserted in the slot.
4. The tape will automatically start playing. Use the volume

control knob to adjust the volume.

5. To fast forward, HALFWAY press the eject button on the cassette tape slot. To stop fast forwarding, repeat this process.
6. To stop and eject the cassette tape, press the eject button on the cassette tape slot completely.
7. When one side of the tape finishes playing, the cassette will automatically stop.
8. NOTE: Remove the tape from the unit when it is not in use or stopped.

QUICK START – Playing Music via Bluetooth

1. Turn on the device by pressing the “VOLUME” (right) knob inward.
2. Set the “FUNCTION” (left) knob to “BT.”
3. On your phone, tablet, or computer, search for the Bluetooth device named “ClearClick VT33.” Connect to this device.
4. Start playing music on your phone, tablet, or computer.

5. Use the volume control knob on the turntable to adjust the volume. (Note: You may also need to adjust the volume on your phone or tablet.)

QUICK START – Playing Music via Line-In/Aux-In

1. Turn on the device by pressing the “VOLUME” (right) knob inward.
2. Set the “FUNCTION” (left) knob to “AUX.”
3. Using a 3.5mm-to-3.5mm aux cable, connect your phone, tablet, or MP3 player to the radio’s “AUX-IN” jack in the back of the device.
4. Start playing music on your phone, tablet, or MP3 player.
5. Use the volume control knob on the turntable to adjust the volume. (Note: You may also need to adjust the volume on your phone or tablet.)

QUICK START – Playing Music via USB Drive

1. Turn on the device by pressing the “VOLUME” (right) knob inward.
2. Set the “FUNCTION” (left) knob to “USB.”
3. Plug in a USB drive that contains music files (MP3, APE,

FLAC, WAV and WMA files). **NOTE: The USB drive must be 64GB or less.**

4. The turntable will start playing tracks from the USB drive. Use the volume control knob on the turntable to adjust the volume.
5. To pause playback, press the PLAY/PAUSE button. Press the PLAY/PAUSE button again to resume playback. To stop playback, press the STOP button.
6. Press the FORWARD SKIP BUTTON to skip next track. Press the BACKWARD SKIP BUTTON to skip previous track.
7. To repeat a single track, choose the track that you want to repeat, then press the PLAY BUTTON to start the track. Press the REPEAT BUTTON once to repeat this track.
8. To repeat all tracks, press the REPEAT twice to repeat all tracks. Once the USB ends, it will start over again from the beginning of the USB.

QUICK START – Recording Music to USB Drive

1. Put a USB drive (**64GB or less**) into the USB slot.
2. Change the mode to a mode (such as PHONO or FM).
3. Press the R (recording) button (to the left of the CD player).
4. The device will record music to the USB drive.
5. To stop recording, press the R (recording) button (to the left of the CD player) again.
6. After you stop recording, the files will be saved in files marked “RECORD” on the USB drive.
7. NOTE: Do not switch modes while recording. Do not remove the USB drive until you stop recording.

PROGRAMMED PLAYBACK (CDs)

(Advanced Feature)

1. Press the PROGRAM BUTTON in “CD” mode (with CD stopped playing). **P01** will be shown on display.
2. Press the FORWARD SKIP BUTTON **▶▶** or BACKWARD SKIP BUTTON **◀◀** to select the tracks.
3. Press the PROGRAM BUTTON again to store the selected track number.
4. Repeat step 2 and 3 above to program other tracks.

5. Press the PLAY/PAUSE button to start programmed playback.

6. To erase the programmed sequence, press the STOP button twice, **OR** the programmed tracks will also erase when the CD DOOR is opened.

Device Diagram & Features

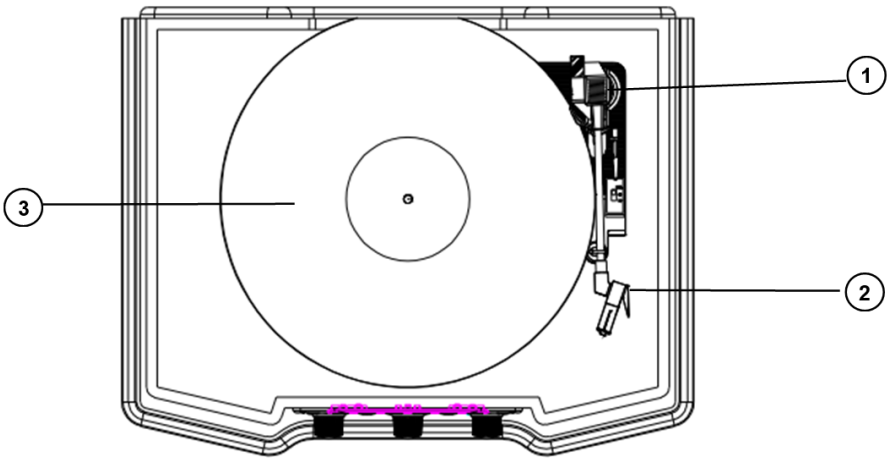
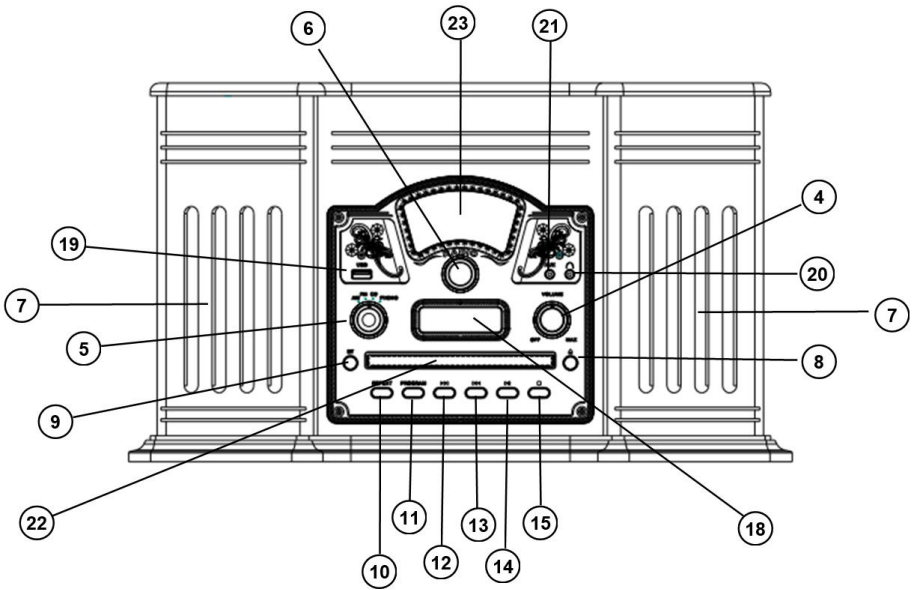

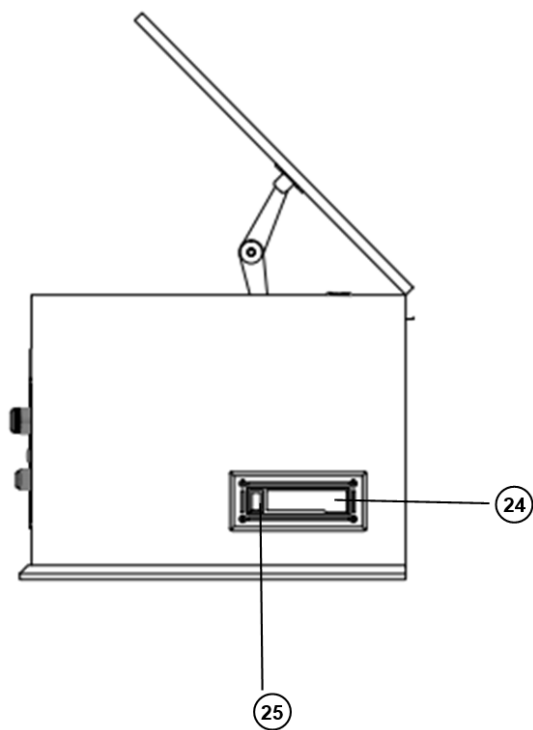
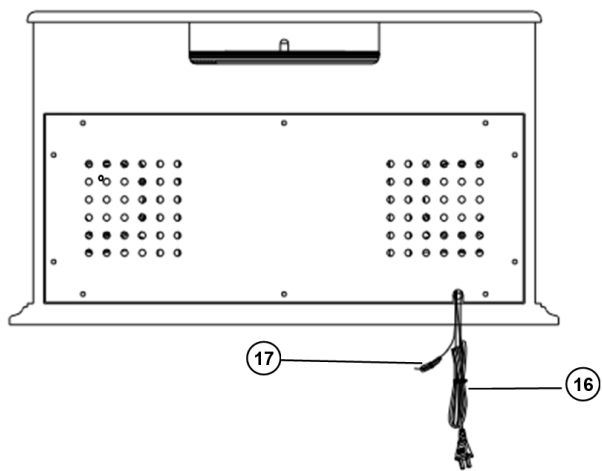

1. TONE ARM
2. STYLUS GUARD
3. TURNTABLE
4. ON/OFF VOLUME CONTROL KNOB
5. FUNCTION SWITCH
(PHONO/TAPE/AUX IN/BT/AM/FM/CD/USB)
6. TUNING KNOB
7. SPEAKERS
8. CD OPEN BUTTON
9. USB RECORDING BUTTON
10. REPEAT BUTTON
11. PROGRAM BUTTON
12. BACKWARD SKIP BUTTON
13. FORWARD SKIP BUTTON
14. PLAY/PAUSE BUTTON
15. CD STOP BUTTON
16. AC POWER CORD
17. FM WIRE ANTENNA
18. CD DISPLAY
19. USB PORT
20. HEADPHONE JACK
21. AUX IN JACK
22. CD LOADING TRAY
23. RADIO DIAL
24. CASSETTE DOOR
25. CASSETTE EJECT/FAST
FORWARD BUTTON

Troubleshooting

1. The USB function isn't working.

Make sure your USB drive contains files in the following formats: MP3, APE, FLAC, WAV and WMA files.

Make sure your USB drive is 64GB or less.

2. In Bluetooth or aux-in mode, the radio's volume is turned up all the way, but the sound isn't loud enough.

Make sure you have turned up the volume on your phone, tablet, or MP3 player as well.

3. I need further assistance or information on the product's warranty.

Just email us at support@clearclick.com, and we'll get right back to you! If you haven't heard back from us within 1-2 business days, please check your "Spam" folder in your email.



www.ClearClick.com