

ClearClick® All-In-One Turntable

With FM Radio, CD Player, Bluetooth, & Line In

Quick Start Guide & User's Manual



Model TT54



Full 5-Year Warranty +

FREE USA-Based Tech Support

If you have any issue or question regarding this product, **contacting us directly** is the fastest way to resolve the issue. We are ClearClick®, a small USA-based business, and we stand behind our products with a full 5-year warranty & free USA tech support. If you have any issues with our product, **please contact us at support@clearclick.tech**.



www.ClearClick.tech

Register Your Product & Browse Our Products

Thank you for your purchase! Make sure you register your product & check out our other unique & easy-to-use technology at:

www.ClearClick.tech

Safety Precautions

1. Do not disassemble the unit.
2. Do not operate the unit around water or rain. Do not operate the unit around any kind of machines or appliances (other than computers).
3. Turn off and unplug the unit when not in use.
4. Do not allow young children to use this device.

Thank You!

Thank you for your purchase of the ClearClick® All-In-One Turntable (Model TT54)! We appreciate your business.

At ClearClick®, we try to make our technology as clear to understand and use as possible. But if you get stuck at any point, you qualify for FREE USA-based tech support as a ClearClick® customer. Just email us at: support@clearclick.tech

(Make sure you explain your issue in detail and tell us that you're using our ClearClick® All-In-One Turntable - Model TT54. Our USA-based tech support team members will normally reply to you within 24-48 business hours.)

QUICK START – Powering Device

1. Securely plug the power plug into the back of the device (into the "DC IN" jack).
2. Plug the other end of the power cord into a power outlet.
3. Switch the "ON/OFF" switch in the back of unit to "ON."
4. Press the "Standby" button to switch the turntable on.
5. When you're done using the device, you may put it in "standby" (low power usage) mode by pressing the "Standby" button. To turn it off completely, switch the "ON/OFF" switch in the back of the unit to "OFF."

QUICK START – Listening To Records

1. Press the "FUNCTION" button several times until "PHONO" is displayed on the front of the device.
2. Remove any plastic protective covers on the turntable needle. Remove any black protective twist ties on the turntable "arm".
3. Place a record on the turntable and select the desired speed (33/45/78) according to the record.
NOTE: If you are playing a 45 RPM record, use the



included 45 RPM adapter located in the holder near the tone arm.

4. Open the tone arm clip to release the tone arm. Place the tone arm onto the record. The turntable will begin to spin and play after the needle is placed on the record.
5. Use the volume control knob to adjust the volume.
6. If the Auto Stop Control Switch is turned ON, the record will stop automatically when finished. If Auto Stop Control Switch is turned OFF, the record will NOT stop automatically when finished.

NOTE: The AUTO STOP function works with most 33 RPM vinyl records. However, it may not work with all records.

QUICK START – Listening To FM Radio

7. Press the “FUNCTION” button several times until “FM” is displayed on the front of the device.
8. Use the tuning knob to select your desired radio station.
9. Use the volume control knob to adjust the volume.
10. To have the device search for all available radio stations & save them as preset stations, hold down the

“PLAY/PAUSE”  button for two seconds. Allow the radio to search for stations. After it is done, you may skip through saved radio stations by pressing the “SKIP BACK”  button or “SKIP FORWARD”  button.

Note: To improve the reception of the radio, simply adjust the pigtail antenna in the back of the device.

QUICK START – Listening To CD’s

1. Press the “FUNCTION” button several times until “CD” is displayed on the front of the device.
2. Press the “OPEN/CLOSE” button to open the CD tray.
3. Load a CD into the tray (label side up). Close the tray by pressing the “OPEN/CLOSE” button again.
4. After several seconds, the CD will automatically start playing. Adjust the volume with the volume control knob.
5. More details on using the CD player:

To pause/resume playback: press the “PLAY/PAUSE”  button.

To stop playback: press “STOP”  button.

To skip backwards through tracks: press the “SKIP BACK”  button.

To skip forwards through tracks: press the “SKIP FORWARD”  button.

QUICK START – Playing Music via Bluetooth

1. Press the “FUNCTION” button several times until “BT” is displayed on the front of the device.
2. On your phone, tablet, or computer, search for the Bluetooth device named “ClearClick Turntable.” Connect to this device.
3. Start playing music on your phone, tablet, or computer.
4. Use the volume control knob on the device to adjust the volume. (Note: You may also need to adjust the volume on your phone or tablet.)

QUICK START – Playing Music via Line-In/Aux-In

1. Press the “FUNCTION” button several times until “AU” is displayed on the front of the device.
2. Using a 3.5mm-to-3.5mm aux cable (not included), connect your phone, tablet, or MP3 player to the turntable’s “AUX IN” jack in the back of the device.
3. Start playing music on your phone, tablet, or MP3 player.
4. Use the volume control knob on the device to adjust the volume. (Note: You may also need to adjust the volume on your phone or MP3 player.)

QUICK START – Recording Music To MP3

To record (digitize) music from records, FM radio, Bluetooth, or aux-in:

1. Plug in a USB flash drive into the “USB” port on the front of the turntable.
2. Start playing music from a record, FM radio station, Bluetooth, or aux in.
3. Press the “REC” record button on the device.
4. After a few seconds, the device will start recording the

music to digital MP3.

5. To stop recording, you must press the “STOP”  button. The device will save the digital MP3 file onto your USB flash drive.

NOTE: There are many types of USB flash drives. If yours does not work with the device, please try another USB drive.

To record (digitize) music from audio CD's:

1. Plug in a USB flash drive into the “USB” port on the front of the turntable.
2. Start playing a CD.
3. To record a **SINGLE CD TRACK** to MP3:
 - a. Press the “REC” button.
 - b. When the word “ONE” appears on the front of the device, press the “REC” button to confirm.
 - c. Press the “SKIP”  button to select which track number to transfer to MP3.
 - d. With the correct track number selected, press the “REC” button to start recording.

- e. The device will start playing and recording the track to MP3. You must allow the device to play the whole track to transfer it. The device will automatically stop recording once the track is done playing, or you may press the “STOP” ■ button anytime.

4. To record an ***ENTIRE CD to MP3 format:***

- a. Press the “REC” button.
- b. When the word “ONE” appears on the front of the device, press the “SKIP” ►► button
- c. When the word “ALL” appears on the front of the device, press the “REC” button.
- d. The device will start playing and recording the entire CD to MP3 format. You must allow the device to play the whole CD to transfer it. The device will automatically stop recording once the CD is done playing, or you may press the “STOP” ■ button anytime.

NOTE: There are many types of USB flash drives. If yours does not work with the device, please try another USB drive.

QUICK START – Playing MP3’s from USB

To play MP3’s from a USB flash drive:

1. Plug in a USB flash drive into the “USB” port on the front of the turntable.
2. Press the “FUNCTION” button several times until “USB” is displayed on the front of the device.
3. The device will automatically start playing MP3 files from the USB drive. Use the volume control knob on the front of the device to adjust the volume.

To pause/resume playback: press the “PLAY/PAUSE”  button.

To stop playback: press “STOP”  button.

To skip backwards through tracks: press the “SKIP BACK”  button.

To skip forwards through tracks: press the “SKIP FORWARD”  button.

Using External Speakers or Headphones

To use headphones or external speakers with the turntable, connect them to the device through either the “headphone” jack or “RCA” jacks on the back of the device.

Turntable Diagram & Features

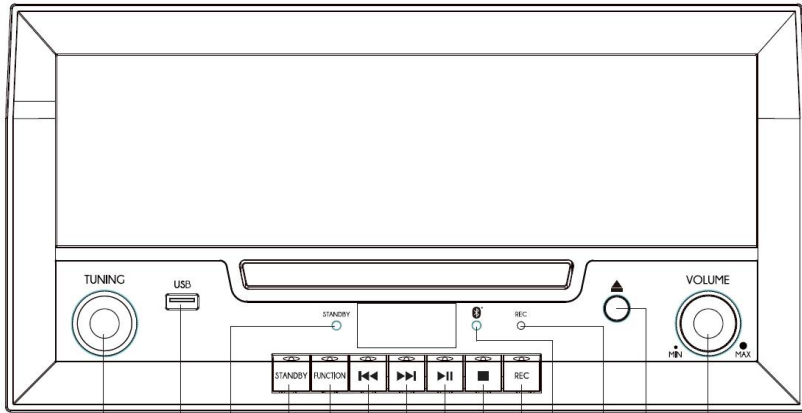

- 1
- 2
- 3
- 4
- 5
- 6
- 7
- 8
- 9
- 10
- 11
- 12
- 13
- 14

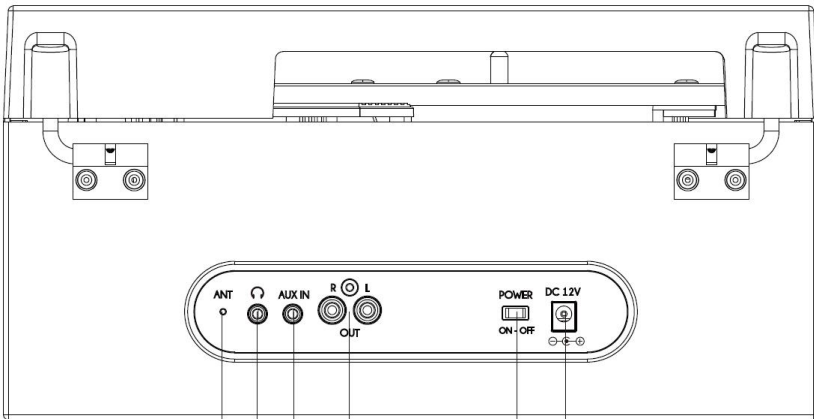

- 15
- 16
- 17
- 18
- 19
- 20

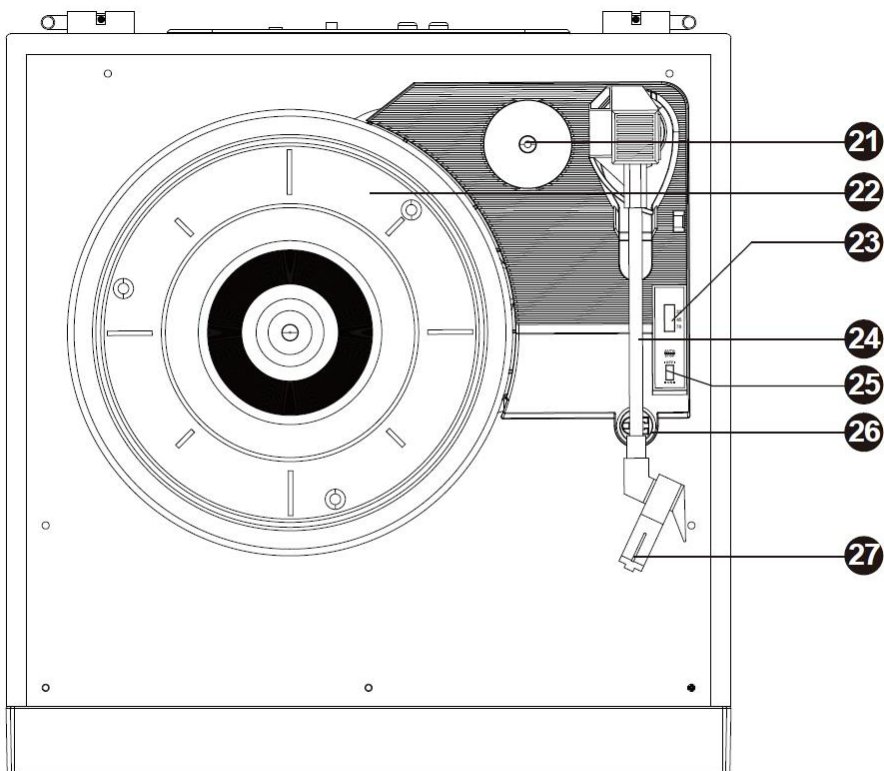

1. Tuning knob
2. USB port
3. Standby indicator light
4. "STANDBY" button

5. "FUNCTION" button
6. "SKIP BACK" button
7. "SKIP FORWARD" button
8. "PLAY/PAUSE" button
9. "STOP" button
10. "RECORD" button
11. Bluetooth indicator light
12. Recording indicator light
13. "OPEN/CLOSE" button
14. Volume control knob
15. Antenna
16. Headphone jack
17. Line-in/Aux-in jack
18. RCA output jacks
19. "ON/OFF" power switch

20. "DC 12V" power-in jack
21. 45 RPM adaptor
22. Turntable platter
23. Speed selector
24. Tonearm
25. "AUTO STOP" on/off switch
26. Tonearm lock
27. Cartridge/needle



Full 5-Year Warranty +

FREE USA-Based Tech Support

If you have any issue or question regarding this product, **contacting us directly** is the fastest way to resolve the issue. We are ClearClick®, a small USA-based business, and we stand behind our products with a full 5-year warranty & free USA tech support. If you have any issues with our product, **please contact us at support@clearclick.tech**.



www.ClearClick.tech